

ACCURATELY MEASURE YOUR WATER USAGE

Change your water filter exactly when you need to with the Flow Totalizer.

Save time and money on unnecessary filter replacements by keeping track of your treated gallons with the Flow Totalizer. Water plays a significant role in the taste of beverages and food. High-quality menu items need high-quality ingredient water, making the right water filtration solution a critical part of any operation. The Flow Totalizer helps reduce costs by keeping track of treated gallons which means you'll save money on unnecessary filter replacements and time on quarterly and annual maintenance.



Flow Totalizer

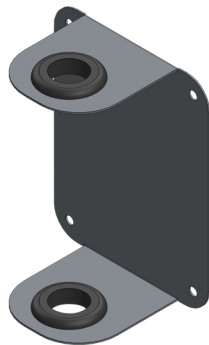

Mounting Bracket



Sustainability

Minimize your use of carbon cartridges - greatly reducing your carbon footprint and landfill impact



Measure

Track your usage and know when to change your filter

Flow Totalizer | FT

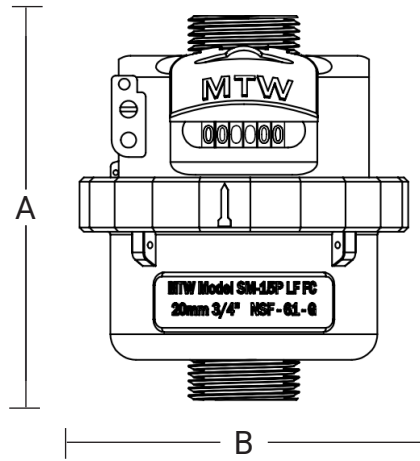

Features:

- Keeps track of lifetime water usage
- Contains oscillating piston that measures gallons (flows from 0.25 gpm - 15 gpm)
- Can be mounted horizontally or vertical
- Includes built in strainer
- Optional mounting bracket - PN 7002801

Flow Totalizer and Digital Control Enclosure

Dimensions

Model Mfg. No.	Operating Range	Max Operating Pressure	Max Operating Temp	Width (A)	Length (B)	Height (C)	Connection	Meter Type	Power Source
Flow Totalizer 9710150	0.25 - 15 GPM	150 PSI (1034 kPa)	120 °F (48°C)	3.85" (97.8 mm)	4.5" (114.3 mm) (8.5" with coupling)	N/A	3/4" NPT	Pulse	N/A

