

72" GREEN FLAME RANGES

GAS TYPE: NATURAL LP



- ARGF-12
- ARGF-24G-8B
- ARGF-36G-6B
- ARGF-48G-4B

STANDARD FEATURES

- Electronic ignition no standing pilots
- Stainless steel sides, front, and 6" deep front landing ledge
- Adjustable 6" steel legs
- Choice of: 6" high stainless-steel stub back, high riser, or high riser with shelf at no charge
- Unit requires 115v power connection, plug and cord provided
- Two year limited warranty, parts, and labor

OPEN BURNERS

- 12" x 12" cast-iron top grates
- 22,000 BTU/hr. burners with electronic ignition, no standing pilot
- Removable full-width drip pan under burner

STANDARD OVEN *(Two Standard 26 1/2" Ovens)*

- Steel oven burner rated at 35,000 BTU/hr
- Oven dimensions: 26 1/2"W x 22 1/2"D x 13 1/2"H.
- Thermostat ranging from 250°F to 500°F (121°C to 260°C)
- Oven Door: Spring assisted, counterweight door
- Two chrome plated oven racks on all oven bases
- Two fixed rack positions
- Porcelain enamel oven interior for easy cleaning
- 100% safety gas shut off

CONVECTION OVEN *(In place of standard oven)*

- Steel oven burner rated at 30,000 BTU/hr.
- Single phase blower motor 4 amp, 60 hz
- Full size sheet pans only fit side-to-side
- Chrome rack guides with five tray positions

GRIDDLES

- 1" thick steel griddle plate
- One burner every 12", rated at 20,000 BTU/hr.
- Stainless steel pilot for each burner for electronic ignition
- Manual control valve for each burner

AVAILABLE OPTIONS

- Swivel Casters (Set of six – three with front brakes)
- Storage Cabinet Base (In place of standard oven)



Model Shown ARGF-12

Shown with optional casters

DESCRIPTION

American Range, green flame range size 72" x 32-1/2" x 56" Stainless steel front, sides, backriser, shelf and 6" adjustable legs. Removable full-width drip pan. Choose 22,000 BTU/hr. open burners with electronic ignition, no standing pilots. 20,000 BTU/hr. 12" section griddle or a combo burner griddle. Heavy-duty cast iron grates, 12" x 12". Burner knobs are cool to the touch, high temperature material. Two ovens: 35,000 BTU/hr. standard oven, 30,000 BTU/hr. for convection with porcelain interior and inside door panel, oven interior measures 26-1/2"W x 22-1/2"D x 13-1/2"H. Oven thermostat adjusts from 250°F to 500°F. All ovens supplied with two racks. Oven door with a spring assisted, counterweight mechanism requiring no adjustment. Rear gas connection and pressure regulator included. 115v power connection, plug and cord provided.



72" GREEN FLAME RANGES with two 26 1/2" ovens

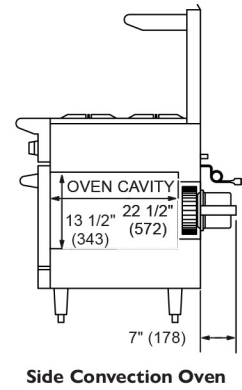
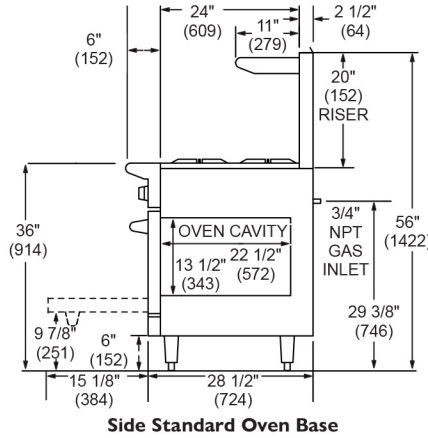
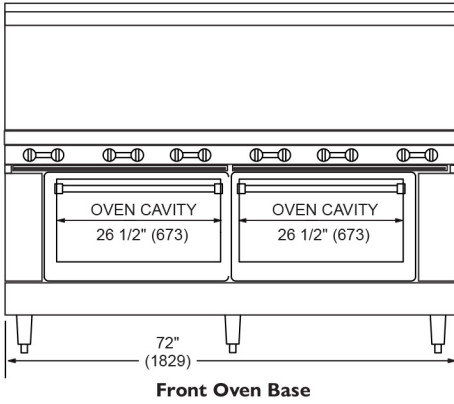

Shipping Weight*

TOP	MODEL	BTU/hr.	(KW)	BURNERS	GRIDDLE SIZE	LBS	(KG)
	ARGF-12	370,000	(108)	12	N/A	1021	(463)
	ARGF-12-CC	360,000	(106)	12	N/A	1167	(529)
	ARGF-24G-8B	310,000	(91)	8	24" (610 MM)	1075	(488)
	ARGF-24G-8B-CC	300,000	(88)	8	24" (610 MM)	1221	(554)
	ARGF-36G-6B	280,000	(82)	6	36" (914 MM)	1100	(499)
	ARGF-36G-6B-CC	270,000	(79)	6	36" (914 MM)	1246	(565)
	ARGF-48G-4B	250,000	(73)	4	48" (1219 MM)	1145	(519)
	ARGF-48G-4B-CC	240,000	(70)	4	48" (1219 MM)	1291	(586)

COMBUSTIBLE WALL CLEARANCES:

For use only on non-combustible floors. Legs or casters are required, or 2" (51) overhang is required when curb mounted. Clearance from non-combustible walls is 0".

When unit is placed next to combustibles walls, clearances must exceed 12" (305) from sides, and 4" (102) from rear.

Commercial cooking equipment requires an adequate ventilation system. For additional information, refer to the National Fire Protection Association's standard.

NFPA96 "Vapor Removal from Cooking Equipment." (NOTE: For North America only)

American Range is a quality manufacturer of commercial cooking equipment. Because of continuing product improvements these specifications are subject to change without prior notice.

Specify type of gas and altitude if over 2000 feet.

Please specify gas type when ordering.

"C" = Convection Oven, "SB" = Storage Base, "G" = Manual Griddle Top. Griddle on the left.

Combo base options available – choose standard, convection, or storage base. contact the factory for other options.

CONVECTION OVEN ELECTRICAL		
VOLTAGE	PHASE	AMPS
120	1	4

MANIFOLD PRESSURE		
NATURAL GAS	PROPANE GAS	MANIFOLD SIZE
5.0" W.C.	10.0" W.C.	3/4" (19MM)

*Shipping weight includes packaging and is approximate.

115v 3 prong plug and cord provided.

DESIGNED & BUILT IN USA
PROFESSIONAL COOKING EQUIPMENT
A70444 Rev B 12182025



AMERICAN RANGE
A Hatco COMPANY

13592 Desmond St Pacoima CA 91331
T. 818.897.0808 Toll Free: 888.753.9898
www.AmericanRange.com