

Cook & Hold Oven

300-TH

ALTO-SHAAM

Original Cook & Hold Ovens produce better food quality and higher yields with built-in savings.

Gentle, radiant Halo Heat® technology evenly surrounds food without the use of extremely hot elements, added humidity or fans. This controlled, uniform heat maintains precise temperatures throughout the cooking and holding process—improving food quality and extending hold times.

Cook by time or probe with Simple or Deluxe controls. Probes sense internal product temperature and automatically convert the oven from cook mode to hold mode once set parameters have been reached.

Labor-free, overnight cooking and effortless operation reduces labor costs and increases productivity.

Place anywhere with a ventless, waterless design. Lower costs with energy efficient operation and no water hookups or traditional kitchen hood required. All Alto-Shaam Cook & Hold Ovens are EPA 202 Certified ventless.

Advanced controls – designed intentionally simple – feature an intuitive, user-friendly interface and programmable recipes to ensure consistency with each cook.

ChefLinc™, cloud-based remote oven management software, streamlines processes and maximizes profits with data-driven insights [Deluxe model only].

ISO 9001:2015-certified

Standard Features

- 3/4" [19mm] non-skid rubber feet
- Single-point, straight removable probe
- Drip tray and drip pan
- Programmable, touchscreen control on Deluxe model
- Programmable control on Simple model
- HACCP data collection on Deluxe model
- Easy recipe upload/download via USB port
- SureTemp™ heat recovery on Deluxe model
- Two [2] stainless steel side racks with seven [7] pan positions spaced 1-3/8" [35mm] on centers
- Removable exterior drip tray"



CAPACITY

3 Full-size pans—20" x 12" x 2-1/2"
GN 1/1—530mm x 325mm x 65mm

6 Half-size pans—10" x 12" x 2-1/2"
GN 1/2—265mm x 325mm x 65mm

Weight maximum: 36 lbs. [16 kg]
Volume maximum: 22.5 quarts [21.3 liters]

Two [2] shelves included. Additional shelves required for maximum capacity.



Shown with Deluxe control



Shown with Simple control

300-TH

Configurations (select one each)

Models

- Simple
 - HACCP option
- Deluxe
 - Ethernet option [5032090]

Door Choice

- Right hinged, solid door, standard
- Left hinged, solid door

Electrical

- 120V, 1Ph
- 230V, 1PH

Casters

- 3" [76mm] casters, two [2] rigid two [2] swivel with brake, option [5029959]

Optional Accessories (select all that apply)

Additional Probes

- Sous vide probe [PR-36576]
- T-handle probe, up to three [3] with Deluxe [PR-46998]
- Straight probe, up to three [3] with Deluxe [qty one [1] included with oven] [PR-46999]

Shelves and Holders

- Shelf, stainless steel [SH-2326]
- Carving holder, prime rib [HL-2635]
- Carving holder, steamship [cafeteria round] [4459]

Cleaners

- Alto-Shaam, non-caustic cleaner one [1] 32-ounce bottle [CE-46828]
- Alto-Shaam, non-caustic cleaner six [6] 32-ounce bottles [CE-46829]



On all Cook & Hold heating elements (excludes labor)



ANSI/NSF 4

Cook & Hold Oven

300-TH

ALTO-SHAAM

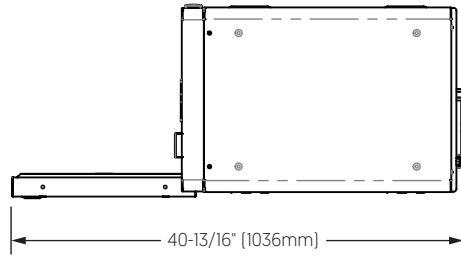

Shown with Simple control and standard feet

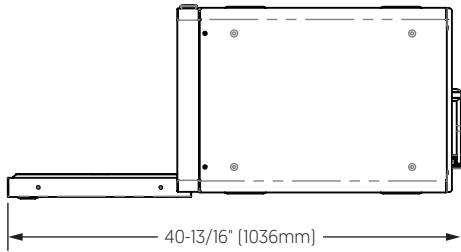
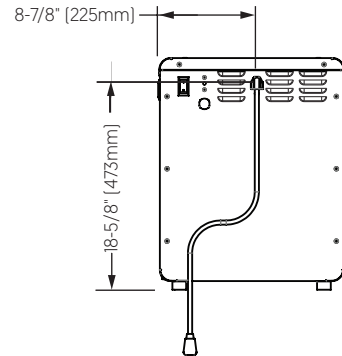
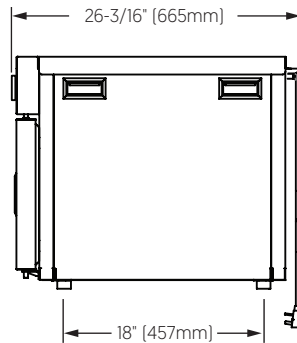
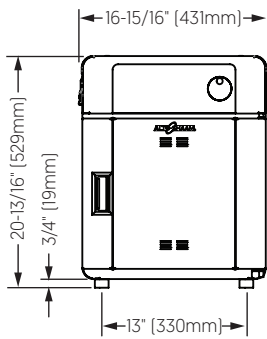

Shown with Deluxe control and 3-1/2" casters

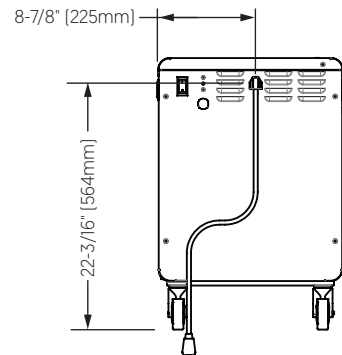
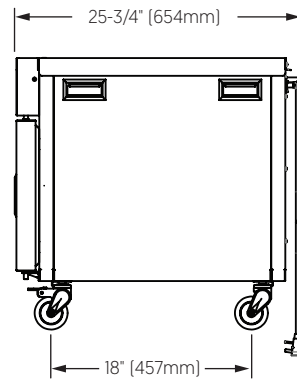
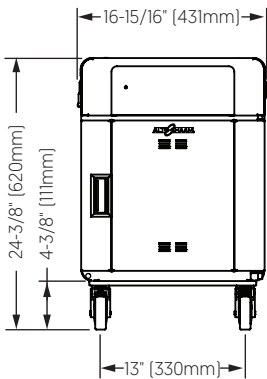

Interior (H x W x D)	Net Weight	Ship Dimensions (L x W x H)	Ship Weight
12-1/2" x 13-11/16" x 21-1/2" [318mm x 348mm x 546mm]	100 lbs. [45 kg]	35" x 23" x 41" [889mm x 584mm x 1041mm]	165 lbs. [75 kg]

Cook & Hold Oven

300-TH



Top:..... 2" [51mm]
 Left:..... 2" [51mm]
 Right:..... 2" [51mm]
 Back: 3" [76mm]



The oven must be installed level.
 The oven must not be installed in any area where it may be affected by steam, grease, dripping water, high temperatures, or any other severely adverse conditions.



Heat of rejection

300-TH	Heat Gain qs, BTU/hr	Heat Gain qs, kW
	162	0.05



Cooking temperature range:
 200°F–325°F [94°C–163°C]
Holding temperature range:
 85°F–205°F [29°C–96°C]



300-TH	v	Ph	Hz	Awg	IEC	A	Breaker (A)	kW	Plug Configuration
120V	120V	1	60	14	—	6.7	15	0.8	NEMA 5-15P 15A-125V plug
230V	230V	1	50/60	14	—	3.2	16	0.8	CEE 7/7 CH2-16P BS-1363 Plugs rated 250V

Electrical connections must meet all applicable federal, state, and local codes.

CONTACT US

W164 N9221 Water Street | Menomonee Falls, Wisconsin 53051 | U.S.A.
 Phone: 262.251.3800 | 800.558.8744 U.S.A./Canada | Fax: 262.251.7067 | alto-shaam.com